

# NEAR EMBEDDINGS OF HYPERCUBES INTO CAYLEY GRAPHS ON THE SYMMETRIC GROUP

by

Zevi Miller

Dept. of Mathematics and Statistics  
Miami University  
Oxford, Ohio 45056

Dan Pritikin

Dept. of Mathematics and Statistics  
Miami University  
Oxford, Ohio 45056

I.H. Sudborough\*

Computer Science Program  
University of Texas - Dallas  
Richardson, Texas 75083

\*This author's research was done during Spring semester 1991 as a visiting professor in the Department of Mathematics and Statistics at Miami University.

## Abstract

In this paper we investigate simulations of hypercube networks by certain Cayley graphs on the symmetric group. Let  $Q(k)$  be the familiar  $k$ -dimensional hypercube, and let  $S(n)$  be the star network of dimension  $n$  defined as follows. The vertices of  $S(n)$  are the elements of the symmetric group of degree  $n$ , two vertices  $x$  and  $y$  being adjacent if  $x \circ (1,i) = y$  for some  $i$ . That is,  $xy$  is an edge if  $x$  and  $y$  are related by a transposition involving some fixed symbol (which we take to be 1). This network (introduced in [AHK]) has nice symmetry properties, and its degree and diameter are sublogarithmic as functions of the number of vertices, making it compare favorably with the

hypercube network. These advantages of  $S(n)$  motivate the study of how well it can simulate other parallel computation networks, in particular, the hypercube.

The first step in such a simulation is the construction of a one-to-one map  $f:Q(k) \rightarrow S(n)$  of dilation  $d$ , for  $d$  small. That is, one wants a map  $f$  such that images of adjacent points are at most distance  $d$  apart in  $S(n)$ . An alternative approach, best applicable when one-to-one maps are hard or impossible to find, is the construction of a one-to-many map  $g$  of dilation  $d$ , defined as follows. For each point  $x \in Q(k)$  there is an associated subset  $g(x) \subseteq V(S(n))$  such that for each edge  $xy$  in  $Q(k)$ , every  $x' \in g(x)$  is at most distance  $d$  in  $S(n)$  from some  $y' \in g(y)$ . Such one-to-many maps allow one to achieve the low interprocessor communication time desired in the usual one-to-one embedding underlying a simulation. This is done by capturing the local structure of  $Q(k)$  inside of  $S(n)$  (via the one-to-many embedding) when the global structure cannot be so captured.

Our results are the following.

- 1) There exist the following one-to-many embeddings:
  - a)  $f:Q(k) \rightarrow S(3k+1)$  with  $\text{dilation}(f) = 1$ ,
  - b)  $f:Q(11k + 2) \rightarrow S(13k + 2)$  with  $\text{dilation}(f) = 2$ .
- 2) There exists a one-to-one embedding  $f:Q(2^{n-1}) \rightarrow S(2^n)$  with  $\text{dilation}(f) = 3$ .

## 1. Introduction

For a graph  $G$ , let  $V(G)$  and  $E(G)$  denote its vertex set and edge set respectively. All graphs in this paper are undirected, loopless, with no multiple edges.

Let  $Q(k)$  denote the graph of the  $k$ -dimensional hypercube.  $V(Q(k))$  is the set of all binary  $k$ -tuples (typically expressed here as binary strings of length  $k$ ), and  $E(Q(k))$  is the set of pairs of points in  $Q(k)$  which differ in exactly one coordinate/bit. It will occasionally be useful to impose the vector space structure of  $(\mathbb{Z}_2)^k$  upon  $V(Q(k))$ , so that we may add two vectors (coordinatewise, modulo 2) and multiply by either of the scalars 0 and 1. For strings  $S_1, S_2, \dots, S_n$  (binary or otherwise), let  $S_1; S_2; \dots; S_n$  denote the larger string formed by concatenating the strings together from left to right in that order, its length being the sum of the lengths of the  $S_i$ 's. Let  $\{0,1\}^*$  be the set of all finite binary strings. Define the map Integer:  $\{0,1\}^* \rightarrow \mathbb{Z}^+ \cup \{0\}$  which sends binary strings (interpreted as integers base 2) to the integers associated with them, e.g.  $\text{Integer}(011) = 3$ .

For a given ordered set of  $n$  symbols  $S = \{s_1, s_2, \dots, s_n\}$ , let  $\text{Perm}(S)$  denote the set of permutations on that set, i.e. the set of all bijections  $f:S \rightarrow S$ . Define the function Sign:  $\text{Perm}(S) \rightarrow \mathbb{Z}_2$  by letting  $\text{Sign}(f) = 0$  when  $f$  is an even permutation, and  $\text{Sign}(f) = 1$  when  $f$

is an odd permutation. For  $i \neq j$ , let  $(i,j)$  denote the transposition  $f$  given by  $f(x) = \begin{cases} s_i & \text{if } x = s_j \\ s_j & \text{if } x = s_i \\ x & \text{otherwise} \end{cases}$ ,

and for  $i \neq 1$  let  $t_i$  denote the particular transposition  $(1,i)$ . We define  $S(n)$ , the vertex-labelled star network graph of dimension  $n$  on the symbol set  $S$ , as follows (equivalent to the definition given in [AHK], where star graphs were first introduced).  $V(S(n)) = \text{Perm}(S)$ , and two vertices/permutations  $f, g \in \text{Perm}(S)$  are defined to be adjacent in  $S(n)$  if there exists an  $i \neq 1$  for which  $g(x) = f(t_i(x))$  [and consequently  $f(x) = g(t_i(x))$ ] for all  $x$ . Observe that  $S(n)$  has  $n!$  vertices, is  $(n-1)$ -regular, and is bipartite with bipartition  $(\text{Sign}^{-1}(0), \text{Sign}^{-1}(1))$ . Figures 1a and 1b illustrate  $S(3)$  and  $S(4)$ , where it is understood in Figure 1b that four edges **a,b,c,d** are not explicitly shown, but their end vertices are as indicated. We also define  $\text{Trans}S(n)$ , the vertex-labelled transposition graph of dimension  $n$  on the symbol set  $S$ . Its vertex set is also  $\text{Perm}(S)$ , and two vertices/permutations  $f, g \in \text{Perm}(S)$  are defined to be adjacent in  $S(n)$  if there exist distinct  $i,j$  for which  $g = f \circ (i,j)$  [and consequently  $f = g \circ (i,j)$ ].

Now let  $G$  and  $H$  be graphs, with  $|V(G)| \leq |V(H)|$ , and  $f:V(G) \rightarrow V(H)$  a one-to-one map. We define the dilation of  $f$ , written dilation( $f$ ), to be the maximum of  $\text{dist}_H(f(x), f(y))$  over all edges  $xy$  of  $G$ . Thus if  $\text{dilation}(f) = d$ , then pairs of adjacent points in  $G$  are sent to pairs of points in  $H$  at distance at most  $d$ , and we call such a map a dilation  $d$  embedding of  $G$  into  $H$ . We will write  $G \subseteq H$  to mean that  $G$  is a subgraph of  $H$ . We denote by  $G^d$  the " $d$ 'th power" of  $G$ , namely, the graph having the same vertex set as  $G$  in which two vertices are joined by an edge if their distance in  $G$  is at least 1 and at most  $d$ . Thus  $G$  can be embedded with dilation  $d$  into  $H$  if and only if  $G \subseteq H^d$ . We write  $S^d(n)$  to denote  $(S(n))^d$ . Note that  $S^1(n) = S(n)$ , that  $\text{Trans}S(n) \subseteq S^3(n)$ , and that if  $d$  is at least the diameter of  $S(n)$ , then  $S^d(n)$  is a complete graph, so that every graph on  $n!$  or fewer vertices embeds with dilation  $d$  into  $S(n)$  for  $d$  that large.

The problem of minimizing dilation in graph embeddings has a large literature, motivated in part by the need to find good simulations of algorithms designed "originally" for some network  $G$  but requiring an implementation on some other network  $H$ . Each communication between adjacent processors  $x$  and  $y$  in the network  $G$  becomes, under the simulation, a communication between corresponding processors  $f(x)$  and  $f(y)$  in  $H$  that are at distance possibly as large as  $\text{dilation}(f)$ . The simulation thus experiences a possible slowdown proportional to a factor of  $\text{dilation}(f)$ , since we take the communication time between two vertices in a network to be proportional to the distance between them. We mention [BCHLR] and [MS] as just two examples of the extensive literature on this topic. In much of this literature the study of simulations includes the analysis of both dilation and routing issues. In this paper we address only the dilation issue, so for our purposes the smaller the dilation of an embedding the better is the associated simulation.

In this paper our purpose is to find simulations of hypercube structures within star networks for which the dilation is near optimal. In line with the preceding discussion, this is done by constructing correspondences from  $V(Q(k))$  to  $V(S(n))$ . In some cases these will be traditional graph embeddings, and in other cases they will be "one-to-many" embeddings (to be defined later). In either case the final outcome is correspondence whose image is a subnetwork of  $S(n)$  for which the interconnection pattern bears a strong resemblance to that of  $Q(k)$ .

The network  $S(n)$  was introduced in [AHK], where it was convincingly argued that  $S(n)$  has a number of desirable characteristics. It was observed in [AK2] that  $S(n)$  is an example of the well known Cayley graph construction. Specifically,  $S(n)$  is the Cayley graph on the symmetric group  $\Sigma_n$  of degree  $n$  obtained by using the set of transpositions  $\{(1,i) : 1 < i \leq n\}$  as a generating set for  $\Sigma_n$ . The resulting symmetry in  $S(n)$  can then be used to good effect in analyzing fault tolerance and broadcasting in  $S(n)$ . The diameter of  $S(n)$  was shown to be  $\lfloor \frac{3(n-1)}{2} \rfloor$  in [AK2]. Since  $S(n)$  is regular of degree  $n-1$  and has  $n!$  vertices, we see that  $S(n)$  achieves diameter and degree which are sublogarithmic as functions of the number of vertices. By contrast, the hypercube  $Q(n)$ , being regular of degree  $n$  on  $2^n$  vertices and having diameter  $n$ , has degree and diameter which are logarithmic as functions of the number of vertices. Thus from the standpoint of degree-diameter values  $S(n)$  is clearly superior to  $Q(n)$  as an interconnection network. We also know [AK1] that  $S(n)$  has connectivity  $n-1$ , which is of course the maximum it could be since  $S(n)$  is  $(n-1)$ -regular. This gives  $S(n)$  good fault tolerance properties. The problem of broadcasting a piece of information from one vertex in  $S(n)$  to all others was studied in [AHK], where an optimal time  $O(n \log(n))$  parallel algorithm was developed. As observed in [AHK], the idea of this algorithm can be used to construct a dilation 1, one-to-one embedding of the symmetric binary tree of depth  $O(n \log(n))$  into  $S(n)$ . For all these reasons it seems important to develop good simulations on  $S(n)$  of algorithms designed for (or at least currently implemented on) various well known and commonly used networks. Among the latter is the hypercube, and this is the motivation for our work.

In [AK2] a related Cayley graph, the "pancake" graph  $P(n)$ , was studied. Again the underlying group is  $\Sigma_n$ , and the generating set is the set of "prefix reversals"  $\rho_i$ ,  $2 \leq i \leq n$ , where  $\rho_i$  is the permutation  $(1,i)(2,i-1)\dots(\lfloor i/2 \rfloor, \lceil i/2 \rceil)$ . Now  $P(n)$  has sublogarithmic degree  $n-1$ .  $P(n)$  also has sublogarithmic diameter  $O(n)$ , although the exact value of its diameter is currently unknown [GP]. Concerning embeddings, it was shown that there exists a dilation 1 embedding of the depth  $O(n \log(n))$  binary tree into  $P(n)$ . Our results on dilation of embeddings of  $Q(k)$  into  $S(n)$  carry over to similar results on embeddings of  $Q(k)$  into  $P(n)$ , as will be seen at the end of the paper. The transposition graph  $\text{Trans}(n)$  is also a Cayley graph, whose diameter is  $n-1$  at the high cost of being  $C(n,2)$ -regular. While the results of section 4 of this paper are generally concerned with embedding

hypercubes into transposition graphs, these results are mostly important in that the embeddings carry over directly to star network graphs and pancake graphs.

There are a variety of ways to denote permutations on  $S = \{s_1, s_2, \dots, s_n\}$ , i.e. to denote the vertices of  $S(n)$ . One way is to list the images  $f(s_1) f(s_2) \dots f(s_n)$  as a string of symbols, and another way is to list the pre-images  $f^{-1}(s_1) f^{-1}(s_2) \dots f^{-1}(s_n)$  as a string of symbols. Using image-strings to represent vertices, two strings  $f$  and  $g$  are adjacent in  $S(n)$  when for some  $i \neq 1$  it is the case that  $g$  is obtainable from  $f$  by interchanging the symbols in the first and  $i$ th positions of the string  $f$ . Using pre-image strings to represent vertices, two strings  $f$  and  $g$  are adjacent in  $S(n)$  when for some  $i \neq 1$  it is the case that  $g$  is obtainable from  $f$  by interchanging the positions of symbols  $s_1$  and  $s_i$ . Because of these differences in how to switch the positions of two symbols in a string to get an adjacent string in  $S(n)$ , when using image-strings to denote vertices we say that  $S(n)$  is positionally represented on the symbols  $s_1 s_2 \dots s_n$  [position 1 being a special position], and when using pre-image strings to denote vertices, we say that  $S(n)$  is  $s_1$ -represented on the symbols  $s_1 s_2 \dots s_n$  [symbol  $s_1$  being a special symbol]. For example, when  $S(4)$  is positionally represented on the symbols  $AXYZ$ , the string  $YXZA$  represents the permutation  $f$  for which  $f(A) = Y$ ,  $f(X) = X$ ,  $f(Y) = Z$  and  $f(Z) = A$ . The vertices adjacent to  $YXZA$  in  $S(4)$  are represented as  $XYZA$ ,  $ZXYA$  and  $AXZY$ , i.e. the strings obtainable from  $YXZA$  by interchanging the symbol in its first position (which happens to be  $Y$ ) with any other symbol. By contrast, when  $S(4)$  is  $A$ -represented on the symbols  $AXYZ$ , the string  $YXZA$  represents the permutation  $f$  for which  $f(Y) = A$ ,  $f(X) = X$ ,  $f(Z) = Y$  and  $f(A) = Z$ . The vertices adjacent to  $YXZA$  in  $S(4)$  are represented as  $AXZY$ ,  $YAZX$  and  $YXAZ$ , i.e. the strings obtainable from  $YXZA$  by interchanging the symbol A with any other symbol. Figures 1b and 1c illustrate  $s(4)$  when positionally represented on the symbols  $AXYZ$  and when  $A$ -represented on the symbols  $AXYZ$ . Vertices that correspond visually in the two figures may or may not be labelled with the same symbol string, but do in fact correspond to the same permutation, viewing permutations as functions. In  $\text{TranS}(n)$ , whether positionally or  $s_1$ -represented on  $s_1 s_2 \dots s_n$ , two strings  $f$  and  $g$  are adjacent when  $g$  is obtainable from  $f$  by interchanging some two symbols  $s_i$  and  $s_j$ .

Using different choices for the ordered set of symbols  $S = \{s_1, s_2, \dots, s_n\}$  will of course result in isomorphic labelled graphs. When no ordered set  $S$  is specified, as a slight abuse of notation we let  $S(n)$ ,  $[\text{TranS}(n)]$  denote the class of graphs isomorphic to the labelled graph  $S(n)$   $[\text{TranS}(n)]$  respectively, with  $S = \{1, 2, \dots, n\}$ .

Our main results, aimed at near optimal dilation, yield simulations of dilation 1, 2, 3, or 4. There is of course the more general question concerning what tradeoff exists between keeping the expansion ratio  $\frac{|V(S(n))|}{|V(Q(k))|}$  small and keeping the dilation low. In [MPS] we study this tradeoff by no longer requiring near optimal dilation, and instead allowing dilation bounded by some absolute

constant. As a result, we there obtain embeddings with greatly improved (i.e. smaller) expansion ratio.

For small values of  $n$ , Table 1 gives a summary of how large a hypercube can be embedded in  $S(n)$  with extremely small dilation; results for dilation  $\leq 4$  are from this paper while those for larger dilation are from [MPS]. It is likely that some of these table entries can be improved, but the column headed by  $\lfloor \log_2(n!) \rfloor$  indicates the dimension of the largest hypercube which can be embedded in  $S(n)$ , even enduring an absurd dilation equal to the diameter of  $S(n)$ . Therefore that column serves as a gauge for how low one can expect to keep the ratio  $\frac{|V(S(n))|}{|V(Q(k))|}$ .

## 2. Dilation 1 embeddings and one-to-many embeddings

For every  $k > 1$  and every  $n$ , it is impossible to embed  $Q(k)$  in  $S^1(n) = S(n)$ , simply because  $Q(k)$  has a 4-cycle while  $S(n)$  does not. Nevertheless it is desirable if possible to simulate, with a minimum of slowdown, various high dimensional hypercube structures using processors linked via a star network. Indeed we show that it is possible to simulate with dilation 1 the action of processors linked by any given  $Q(k)$  network by using processors linked by a star network of sufficiently high dimension, if we are willing to let several processors of the star network simultaneously do the job of a single processor in the hypercube network.

Let  $\Pi(n) = \{S: S \subseteq V(S(n))\}$  be the power set of  $V(S(n))$ . For a given  $d$ , we say that a map  $f: V(Q(k)) \rightarrow \Pi(n)$  is a one-to-many dilation  $d$  embedding of  $Q(k)$  into  $S(n)$  if for every pair of distinct vertices  $x, y$  in  $Q(k)$ ;

- a)  $f(x) \cap f(y) = \emptyset$ , and
- b) If  $x$  and  $y$  are adjacent in  $Q(k)$ , then for each  $x' \in f(x)$  there corresponds at least one vertex  $y' \in f(y)$  for which  $x'$  and  $y'$  are adjacent in  $S^d(n)$ .

We write  $Q(k) \Rightarrow S^d(n)$  to indicate that there exists a one-to-many dilation  $d$  embedding of  $Q(k)$  into  $S(n)$ . The notion of one to many embeddings originated in [F], where tradeoffs between dilation and expansion ratio are studied for one to many embeddings between hypercubes, grids, and complete graphs.

While the above definition provides a natural reason for referring to such maps as "one-to-many", for convenience we work instead with the following equivalent characterization and notation. Let  $R$  be a non-empty subset of  $V(S(n))$ , consider a map  $F: R \rightarrow V(Q(k))$ , and let  $d$  be given. For each  $r \in R$  and each  $i$ , let  $F_i(r, d)$ , or just  $F_i(r)$  when  $d$  is fixed by context, denote the set of points  $v$  in  $R$  which are adjacent to  $r$  in  $S^d(n)$  (that is, those  $v$  in  $R$  which are at distance at most  $d$  from  $r$  in  $S(n)$ ), and for which  $F(r)$  and  $F(v)$  differ in coordinate  $i$  and in no other coordinate. If  $F_i(r)$  is non-empty for each  $r \in R$  and each  $i = 1, 2, \dots, k$ , then clearly  $Q(k) \Rightarrow S^d(n)$  via the one-to-many dilation  $d$  embedding  $f = F^{-1}$ . Therefore we refer to maps  $F$  with these properties as being one-to-many

embeddings of  $Q(k)$  into  $S(n)$ , even though the direction of the arrow may seem to be the reverse of the natural direction. In this notation, the idea of a one-to-many dilation  $d$  embedding is that when a processor at vertex  $v$  would ordinarily be computing in  $Q(k)$ , each of the processors at the points of  $F^{-1}(v)$  is instead doing exactly the same computation, and that when a processor at vertex  $v$  would ordinarily be sending a message to an adjacent processor at vertex  $w$  in  $Q(k)$ , each point  $r$  in  $F^{-1}(w)$  is such that the processor at  $r$  is instead receiving the equivalent of that same message from some processor at a vertex  $s \in F^{-1}(v)$  adjacent in  $S^d(n)$  to  $r$ . Such a message would travel through up to  $d$  steps in  $S(n)$  instead of just one step in  $Q(k)$ , and might even travel through points not in  $R$ , but the overall effect of a one-to-many embedding is essentially the same as that for the usual sort of dilation  $d$  embedding. There is no trouble extending the notion of one-to-many embeddings between arbitrary graphs, with the same application in mind. Note in particular that if  $f$  is a dilation  $d$  embedding  $G$  into  $H$ , then  $F = f^{-1}$  automatically qualifies as a one-to-many dilation  $d$  embedding of  $G$  into  $H$ . Consequently, if  $Q(k) \subseteq S^d(n)$  then  $Q(k) \implies S^d(n)$ .

Given a map  $F:R \rightarrow V(Q(k))$  which is purportedly a one-to-many dilation  $d$  embedding of  $Q(k)$  into  $S(n)$ , to toggle bit  $i$  of a string  $r \in R$  is to apply a sequence of  $d$  or fewer allowable (depending upon how  $S(n)$  is represented) transpositions to  $r$  and obtain a string in  $F_i(r)$ , thereby demonstrating that  $F_i(r)$  is non-empty. Therefore to show that  $F$  is really a one-to-many dilation  $d$  embedding, it suffices to show how to toggle each bit  $i=1,2,\dots,k$  of each  $r \in R$ . Indeed to demonstrate that  $Q(k) \subseteq S^d(n)$  or that  $Q(k) \subseteq \text{Trans}^d(n)$ , given a proposed one-to-one correspondence  $F:R \rightarrow V(Q(k))$  showing which points  $R$  of  $V(S^d(n))$  or  $\text{Trans}^d(n)$  correspond to which points of  $V(Q(k))$  in the subgraph relationship, it likewise suffices to show how to toggle each bit  $i=1,2,\dots,k$  of each  $r \in R$ .

**Theorem 1:** If  $Q(k) \implies S^1(n)$ , then  $k \leq n-1$ . Furthermore, if  $Q(n-1) \implies S^1(n)$ , then  $n$  is a power of 2. **Proof:** Suppose there exists a one-to-many dilation 1 embedding  $F:R \rightarrow V(Q(k))$  for  $R$  a subset of  $V(S(n))$ . Each  $r \in R$  must have at least  $k$  neighbors in  $S(n)$ , one in each of  $F_1(r), F_2(r), \dots, F_k(r)$ . Since  $r$  has only  $n-1$  neighbors in  $S(n)$ , we have that  $k \leq n-1$ .

Further suppose that  $k = n-1$ . Let  $v, w \in V(Q(k))$  differ in exactly coordinate  $i$ . For each  $r \in F^{-1}(v)$  there exists a unique  $s \in F_i(r)$ , because  $r$  has only  $n-1$  neighbors in  $S(n)$ , and at least one is in each of the disjoint sets  $F_1(r), F_2(r), \dots, F_k(r)$ . In  $S(n)$ , this  $s$  is then the only neighbor of  $r$  in  $F^{-1}(w)$ . By symmetry, in  $S(n)$  each  $s \in F^{-1}(w)$  has exactly one neighbor  $r$  in  $F^{-1}(v)$ . Therefore a one-to-one correspondence exists between  $F^{-1}(v)$  and  $F^{-1}(w)$ , so that  $|F^{-1}(v)| = |F^{-1}(w)|$  for every pair of adjacent  $v$  and  $w$  in  $Q(k)$ . Since  $Q(k)$  is connected, it follows that  $|F^{-1}(v)| = |F^{-1}(w)|$  for all vertices  $v$  and  $w$  in  $Q(k)$ , whether or not adjacent. Therefore  $|F^{-1}(v)| = \frac{|S(n)|}{|Q(n-1)|} = \frac{n!}{2^{n-1}}$  for each vertex  $v$  of  $Q(k)$ . It suffices to show that  $n!$  is divisible by  $2^{n-1}$  if and only if  $n$  is a power of 2.

For  $L = \lceil \log_2 n \rceil$ , notice that the largest integer  $p$  for which  $2^p$  divides  $n!$  is  $p = \sum_{i=0}^L \left\lfloor \frac{n}{2^i} \right\rfloor$ , because  $\left\lfloor \frac{n}{2^i} \right\rfloor$  is the number of the  $n$  factors of  $n!$  which are divisible by  $2^i$ . But  $p = \sum_{i=0}^L \left\lfloor \frac{n}{2^i} \right\rfloor \leq n \sum_{i=0}^L \frac{1}{2^i} = n(1 - \frac{1}{2^L}) = n - \frac{n}{2^L} \leq n - 1$ , with equality in the very last inequality only when  $n$  is a power of 2, and equality throughout (so that  $p = n-1$ ) whenever  $n$  is a power of 2, completing the proof. ■

**Theorem 2:**  $Q(1) \Rightarrow S^1(2)$ ,  $Q(3) \Rightarrow S^1(4)$ ,  $Q(4) \Rightarrow S^1(8)$ , and  $Q(k+1) \Rightarrow S^1(3k+1)$  for all  $k$ .

**Proof:** In fact,  $Q(1)$  is isomorphic to  $S^1(2)$ , establishing the first claim. Next, let  $S(4)$  be A-represented on the symbols  $AXYZ$ . For  $R = V(S(4))$ , consider the map  $F_{3,4}: R \rightarrow V(Q(3))$  [abbreviated as  $F$ ] defined by

$$F(c_1c_2c_3c_4) = b_1b_2b_3 + (b_4 + \text{Sign}(c_1c_2c_3c_4)) [111],$$

where bit  $b_i$  is 1 when  $c_i = A$  and is 0 otherwise. (Note: the second term denotes the vector [111] multiplied by the scalar  $(b_4 + \text{Sign}(c_1c_2c_3c_4))$ .) For example,  $F(AXYZ) = 100 + (0+0) [111] = 100 + 000 = 100$ , while  $F(XAYZ) = 010 + (0+1) [111] = 010 + 111 = 101$ . Figure 1c) shows  $S(4)$ , and for each string  $s \in V(S(4))$ , the visually corresponding point in Figure 1d) is labelled with  $F(s)$ . So, to verify that  $Q(3) \Rightarrow S^1(4)$ , one can verify for each vertex  $v$  in Figure 1d) and each  $i=1,2,3$  that  $v$  and at least one of  $v$ 's neighbors have labels which differ in exactly coordinate  $i$ . But a pictorial approach doesn't help for later examples in which the star and cube dimensions are arbitrarily large. So, to show that  $Q(3) \Rightarrow S^1(4)$ , we now show by more algebraic means how to toggle any of bits 1,2, or 3 of any  $r \in R$ . Let  $i$  be whichever bit one wishes to toggle. If  $b_i = 1$ , then to toggle bit  $i$  it suffices to transpose  $A$  with the symbol in position 4. To see this, note that both  $b_4$  and  $\text{Sign}(c_1c_2c_3c_4)$  are changed, but the scalar  $(b_4 + \text{Sign}(c_1c_2c_3c_4))$  remains unchanged. Also  $b_s$  remains unchanged for  $s \in \{1,2,3\} \setminus \{i\}$  because  $A$  has been moved to position 4 and not to position  $s$ . Hence from the definition of  $F$  above, it follows that  $r$  and  $F(r)$  differ in exactly the  $i$ 'th coordinate, showing that we have toggled bit  $i$ . For the next case, suppose  $b_i = 0$  and  $b_4 = 1$ . Then transposing  $A$  with whatever symbol currently occupies position  $i$  will toggle bit  $i$ . The remaining case is when  $b_i = 0$  and  $b_4 = 0$ , in which case the following will toggle bit  $i$ ; transpose  $A$  with that symbol which is not  $A$ , not in position  $i$ , and not in position 4. For example, to toggle bit 2 of  $XAYZ$ , noting that  $F(XAYZ) = 101$ , we transpose  $A$  with  $Z$  to obtain  $XZYA$ , for which  $F(XZYA) = 000 + (1+0) [111] = 111$ , the neighbor of  $F(XAYZ)$  in  $Q(3)$  differing in bit 2. For another example, to toggle bit 3 of the same  $XAYZ$ , we transpose  $A$  with  $X$  to obtain  $AXYZ$ , for which  $F(AXYZ) = 100$ , the neighbor of  $F(XAYZ)$  differing in bit 3. Details have been omitted in two of the above three cases, but the

reader should verify in those cases that toggling any bit  $i$  of any string  $s$  in  $S(4)$  really is always accomplished by the above description, yielding a neighbor  $s'$  for which  $F(s)$  and  $F(s')$  differ only in bit  $i$ , proving that  $F$  is a one-to-many dilation 1 embedding of  $Q(3)$  into  $S(4)$ .

Let  $G_{3,4}:S(4) \rightarrow Q(3)$  map each vertex of  $S(4)$ , as positionally represented on  $AXYZ$  in Figure 1b), to the label of the corresponding vertex in Figure 1d). Note that  $G_{3,4}$  is really just the analogue of  $F_{3,4}$ . That is, given a point  $r'$  in Figure 1b) and its corresponding point  $r''$  in Figure 1c), we define  $G_{3,4}$  on  $v$  by  $G_{3,4}(r') = F_{3,4}(r'')$ . Thus is a one-to-many dilation 1 embedding of  $Q(3)$  into  $S(4)$ . These maps  $F_{3,4}$  and  $G_{3,4}$  are used in the next paragraph, and again in section 3.

Let  $S(8)$  be positionally represented on the symbols  $A_1X_1Y_1Z_1A_2X_2Y_2Z_2$ . Let  $R$  be the set of those arrangements in which the last four positions are occupied by an  $A$ , an  $X$ , a  $Y$  and a  $Z$ , in that order, but with arbitrary subscripts on them. Given a string  $r$  in  $R$ , delete the last four symbols and delete the subscripts to get a positionally represented permutation  $r'$  in  $S(4)$  on the symbols  $AXYZ$ , and let  $B = G_{3,4}(r')$  [so  $B$  is the 3-digit bit string at the vertex in Figure 1d) corresponding to  $r'$  in Figure 1b)]. Now define the map  $F:R \rightarrow Q(4)$  by

$$F(r) = B;p$$

where  $p = 1$  if the first four symbols of  $r$  include an odd number of symbols subscripted by a 2, and  $p = 0$  otherwise.

We now show that  $F$  is a dilation 1 embedding by sketching how to toggle each of the four bits. To toggle bit 4 of  $r$ , transpose the symbol in position 1 of  $r$  with its counterpart symbol (same letter, different subscript) located in the last four positions. This changes the parity of the number of symbols subscripted by a 2 among the first four positions, and hence changes  $p$  while leaving unchanged the other three bits. As for the first three bits, these can be toggled in the manner that the three bits of  $r'$  are toggled via the map  $G_{3,4}$ . That is, for each  $i$ ,  $1 \leq i \leq 3$ , we know that there is a  $j$ ,  $2 \leq j \leq 4$ , for which interchanging the symbols in positions 1 and  $j$  toggles bit  $i$  of  $r'$  relative to the map  $G_{3,4}$ . Then interchanging symbols in position 1 and  $j$  of  $r$  also toggles bit  $i$  of  $r$ . We have thus shown how to toggle any of the four bits, so it follows that  $F$  is a one-to-many dilation 1 embedding of  $Q(4)$  into  $S(8)$ . The following is an illustration of  $F$  and its toggling action. Letting  $r = Z_2A_2Y_1X_1X_2Y_2Z_1A_1$ , the image  $F(r)$  is evaluated as follows. Because there are an even number (two) of 2's appearing as subscripts among the first four symbols,  $p=0$ . We have  $r' = ZAYX$  obtained from the first four symbols, so  $B = G_{3,4}(ZAYX) = 111$ . Therefore  $F(r) = 1110$ . To toggle bit 4 of  $r$ , its neighbor  $Z_1A_2Y_1X_1X_2Y_2Z_2A_1$  serves. To toggle bit 2 of  $r$ , we begin by observing that bit 2 of  $r'$  can be toggled by interchanging the symbols in positions 1 and  $j=4$  of  $r'$  to get  $XAYZ$ , as can be verified by noting that  $G_{3,4}(ZAYX)$  and  $G_{3,4}(XAYZ)$  disagree in precisely bit 2 (see Figures 1b) and 1d)). Therefore to toggle bit 2 of  $r$  we interchange the symbols in those same two positions 1 and 4, obtaining the neighbor  $X_1A_2Y_1Z_1X_2Y_2Z_2A_1$ .

Let  $S(3k+1)$  be  $A$ -represented on the symbols  $AX_1Y_1Z_1X_2Y_2Z_2\dots X_kY_kZ_k$ . For each  $i = 1, 2, \dots, k$ , each arrangement of these  $3k+1$  symbols induces a permutation string on the ordered set  $X_iY_iZ_i$ , based upon the left-to-right order in which those symbols appear in the arrangement; let  $b_i$  denote the Sign of that induced permutation. For example, the arrangement  $Y_2Z_3X_1X_3Z_1X_2AZ_2Y_3Y_1$  of the symbols  $AX_1Y_1Z_1X_2Y_2Z_2X_3Y_3Z_3$  induces the permutations  $X_1Z_1Y_1$ ,  $Y_2X_2Z_2$  and  $Z_3X_3Y_3$ , for which  $b_1=1$ ,  $b_2=1$ , and  $b_3=0$ . Consider the map  $F:S(3k+1)\rightarrow Q(k+1)$  defined for each  $c = c_1c_2c_3\dots c_{3k}c_{3k+1}$  by

$$F(c) = b_1;b_2;b_3;\dots;b_k;p,$$

where  $p = \text{Sign}(c) + \sum_{i=1}^k b_i$ , summed modulo 2. For the same example,  $\text{Sign}(Y_2Z_3X_1X_3Z_1X_2AZ_2Y_3Y_1) = 1$ , so  $p = 1+1+1+0 = 1$ , so that  $F(Y_2Z_3X_1X_3Z_1X_2AZ_2Y_3Y_1) = 1101$ . To see that  $F$  is a one-to-many dilation 1 embedding, consider any string  $s$  on the  $3k+1$  symbols, with  $F(s) = b_1;b_2;b_3;\dots;b_k;p$ . To toggle bit  $k+1$  (the parity bit  $p$ ), exchange the symbol  $A$  in  $s$  with whichever of the symbols  $X_1, Y_1, Z_1$  is nearest left-to-right to  $A$  (breaking ties arbitrarily). This changes  $\text{Sign}(c)$  but none of the  $b_i$ 's so that the parity  $p$  switches, thereby toggling bit  $k+1$ . For  $i = 1, 2, \dots, k$ , to toggle bit  $i$ , exchange the symbol  $A$  in  $s$  with whichever one of the symbols  $X_i, Y_i, Z_i$  is such that exactly one of those three symbols appears strictly between its position and the position of  $A$ . This is illustrated in Figure 2. As an example, in  $S(10)$  the string  $s = Y_2Z_3X_1X_3Z_1X_2AZ_2Y_3Y_1$  has the neighbors  $Y_2Z_3X_1X_3Z_1X_2Z_2AY_3Y_1$  (thereby toggling bit 4),  $Y_2Z_3AX_3Z_1X_2X_1Z_2Y_3Y_1$  (bit 1),  $AZ_3X_1X_3Z_1X_2Y_2Z_2Y_3Y_1$  (bit 2) and  $Y_2AX_1X_3Z_1X_2Z_3Z_2Y_3Y_1$  (bit 3). ■

### 3. Dilation 2 embeddings

We now turn to embeddings of dilation bigger than 1. As background we mention the following results proved in [NSK].

**Theorem 3** [NSK]: The following embeddings exist for dilation 2, 3, and 4.

- $Q(n) \subseteq S^2(2^n)$ .
- $Q(n) \subseteq S^3(n)$ .
- If  $Q(d) \subseteq S^4(n)$ , then  $Q(d + \lfloor \log_2(n+1) \rfloor) \subseteq S^4(n+1)$ .

In this section we extend a) by constructing dilation 2 embeddings  $Q(d) \rightarrow S(n)$  having a smaller ratio  $\frac{|S(n)|}{|Q(d)|}$ , though these embeddings are one-to-many. In the next section we improve b), again by obtaining a smaller ratio  $\frac{|S(n)|}{|Q(d)|}$ , this time using one-to-one embeddings. In [MPS] we

develop a generalization of c) which via iteration is then used to obtain bounded dilation one to one embeddings  $Q(d) \rightarrow S(n)$  for which  $d$  is asymptotically  $\frac{n}{2}$  larger than it would be through iteration of c) alone.

Proceeding now to dilation 2 embeddings, we make use of the one-to-many dilation 1 embedding  $F_{3,4}: S(4) \rightarrow Q(3)$  defined in the previous section.

**Theorem 4:**  $Q(11k+2) \Rightarrow S^2(13k+2)$

**Proof:** Let  $S(13k+2)$  be positionally represented on the symbols

$A_1 A_2 A_3 \dots A_{5k+1} X_1 Y_1 Z_1 X_2 Y_2 Z_2 X_3 Y_3 Z_3 \dots X_k Y_k Z_k T_1 T_2 T_3 \dots T_{5k+1}$ . Let  $R$  be the set of those arrangements of these  $13k+2$  symbols having the following features:

- (1) For each  $i$ , if  $T_i$  appears as one of the last  $5k+1$  symbols in an arrangement, then it appears in position  $8k+1+i$ , its "natural" position.
- (2) For each  $i=1,2,\dots,k$ , the three symbols  $X_i, Y_i$  and  $Z_i$  all appear among the eight positions  $8i-6, 8i-5, 8i-4, 8i-3, 8i-2, 8i-1, 8i, 8i+1$ , no two of them in positions  $8i-6$  and  $8i-5$ , no two in positions  $8i-4$  and  $8i-3$ , no two in positions  $8i-2$  and  $8i-1$ , and no two in positions  $8i$  and  $8i+1$ .

We now define a mapping  $F: R \rightarrow V(Q(11k+2))$ . For  $s = c_1 c_2 c_3 \dots c_{13k+2} \in R$ ,  $F(s) = \tau_1 \tau_2 \tau_3 \dots \tau_{5k+1}; x_1 y_1 z_1; x_2 y_2 z_2; x_3 y_3 z_3; \dots; x_k y_k z_k; B_1; B_2; B_3; \dots; B_k; p$ , whose parts are defined as follows. This map is sufficiently complicated that we illustrate it in Figure 3 and also indicate below [in brackets] one step at a time what would transpire should  $k=1$  for the example string  $s = T_2 A_6 Z_1 X_1 T_3 T_5 A_5 A_1 Y_1 T_1 A_4 A_2 T_4 A_3 T_6$ , which is indeed in  $R$ . We define the bit  $\tau_i$  by letting  $\tau_i = 1$  if  $T_i$  is in its natural position, and  $\tau_i = 0$  otherwise [in the example,  $\tau_1 \tau_2 \tau_3 \tau_4 \tau_5 \tau_6 = 100101$ ]. We define the bits  $x_i, y_i, z_i$  by letting  $x_i = 1$  (resp.  $y_i = 1, z_i = 1$ ) if  $X_i$  (resp.  $Y_i, Z_i$ ) is in an odd numbered position, and  $x_i = 0$  (resp.  $y_i = 0, z_i = 0$ ) otherwise [in the example,  $x_1 y_1 z_1 = 011$ ]. We define the 3-digit binary string  $B_i$  by letting  $B_i = F_{3,4}(\text{String}_i)$ , where  $\text{String}_i$  is formed from  $s$  as follows. Form the string of length 8 induced by the symbols in positions  $8i-6, 8i-5, 8i-4, 8i-3, 8i-2, 8i-1, 8i, 8i+1$ , keeping intact the left-to-right order of those 8 symbols but deleting all subscripts in those symbols, to obtain a string  $d_1 d_2 d_3 d_4 d_5 d_6 d_7 d_8$ , among whose symbols should be exactly one  $X$ , one  $Y$  and one  $Z$  (see condition (2) concerning  $R$ ) [in the example, towards determining  $\text{String}_1$ ,  $d_1 d_2 d_3 d_4 d_5 d_6 d_7 d_8 = AZXTTAAAY$ ]. Now form the string  $\text{String}_i = e_1 e_2 e_3 e_4$ , where  $e_k = A$  if neither of  $d_{2k-1}$  or  $d_{2k}$  is one of  $X, Y$  or  $Z$ , but where otherwise  $e_k$  is the unique element in  $\{d_{2k-1}, d_{2k}\} \cap \{X, Y, Z\}$  [in the example,  $e_1 e_2 e_3 e_4 = ZXAY$ , and  $B_1 = F_{3,4}(ZXAY) = 001 + (0+0) [111] = 001$ ]. Roughly speaking,  $\text{String}_i$  is the string induced by the left-to-right order of  $X_i, Y_i, Z_i$

in  $s$ , except for the complication of placing a symbol  $A$  amongst them, and deleting the subscripts. It is important to note that  $\text{String}_i$  is regarded as a string in  $S(4)$  as  $\underline{A}$ -represented on the symbols  $AXYZ$ , despite the fact that  $s$  is a string in  $S(13k+2)$  as positionally represented on a set. To complete the definition of  $F$ , define the bit  $p$  by letting  $p = \text{Sign}(s)$  [in the example,  $p = 1$ , and putting everything together,  $F(s) = 100101;011;001;1 = 1001010110011$ ].

Now we show that  $F$  is a one-to-many dilation 2 embedding. To toggle the bit corresponding to  $\tau_i$  from 1 to 0 (so that  $T_i$  was in its natural position in string  $s$ , and we want to move it out of that position without altering any of the other  $11k+2$  bits), first check whether a  $T$  is in position 1 of  $s$ . If not, then transpose  $T_i$  with the symbol in position 1, then find a symbol among positions 2 through  $8k+1$  which is not an  $X$ ,  $Y$  or  $Z$  and transpose  $T_i$  with that symbol, calling the resulting string  $s'$ . Next we show that this action toggles the  $i$ 'th bit, that is, that  $s' \in R$  and that  $F(s)$  and  $F(s')$  disagree in exactly the  $i$ 'th bit, namely, the bit corresponding to  $\tau_i$ . For checking that  $s' \in R$  holds, first note that (2) holds since no  $X_i, Y_i$ , or  $Z_i$  in  $s$  is moved, so that (2) holds for  $s'$  since it held for  $s$ . As for (1), the interchange of  $T_i$  with the non- $T$  symbol in position 1 affects none of the  $T_m$  of  $s$ ,  $m \neq i$ , while the second move affects none of the last  $5k+1$  positions. Hence the validity of (1) for  $s'$  follows from its validity for  $s$ . This argument likewise shows that the first  $5k+1$  bits of  $F(s)$  and  $F(s')$  disagree in exactly the  $i$ 'th bit. Since no  $X_m, Y_m$ , or  $Z_m$  has been moved by this action, it follows that bits  $5k+2$  through  $13k+1$  of  $F(s)$  and  $F(s')$  agree. Finally since  $s'$  is obtained from  $s$  by a sequence of two transpositions, we see that  $F(s)$  and  $F(s')$  agree in the parity bit  $p$ . This completes the verification that the sequence of transpositions leading from  $s$  to  $s'$  serves to toggle the  $i$ 'th bit. In future arguments, we specify a sequence of transpositions to be applied to an  $s \in R$  aimed at toggling a particular bit, and we leave to the reader the verification that the sequence toggles the bit in question. That is,

- (i)  $s' \in R$ , and
- (ii)  $F(s)$  and  $F(s')$  disagree in exactly that particular bit.

Continuing in the case of toggling the bit corresponding to  $\tau_i$  from 1 to 0, suppose instead that a  $T$  had been in position 1 of  $s$ . Then first transpose that symbol in position 1 with a symbol among positions 2 through  $8k+1$  which is not an  $X$ ,  $Y$ ,  $Z$  or  $T$  (such a symbol necessarily exists in  $s$ , since there are only  $8k+1$  such symbols to conceivably occupy those  $8k$  positions, and one of them is in position 1, and  $T_i$  itself is in position  $8k+1+i$ ), then transpose  $T_i$  with whatever symbol is in position  $8k+1+i$ , thereby toggling the bit corresponding to  $\tau_i$  from 1 to 0. To toggle that same bit from 0 to 1, transpose  $T_i$  with whatever symbol is in position 1 (unless  $T_i$  was there) and then transpose  $T_i$  with whatever symbol is in position  $8k+1+i$ . In the case that  $T_i$  was in position 1 of  $s$ , first transpose  $T_i$  with whatever symbol is in position 1, then transpose the symbol now in position 1 with any symbol in positions 2 through  $8k+1$  which is not an  $X$ ,  $Y$  or  $Z$ .

To toggle the bit corresponding to  $x_i$ , suppose that  $X_i$  is in position  $2j+b$  for  $j$  an integer, and  $b = 0$  or  $1$ . Transpose  $X_i$  with the symbol in position  $1$ , then transpose  $X_i$  with the symbol in position  $2j+1-b$ . Toggle any bit corresponding to  $y_i$  or  $z_i$  similarly. To toggle the bit corresponding to  $p$  (the last bit), Transpose the symbol in position  $1$  with any symbol in positions  $2$  through  $8k+1$  which is not an  $X$ ,  $Y$  or  $Z$ , thus changing the parity of the permutation but not altering any other bits.

To toggle the  $j$ th bit among the three bits corresponding to some  $B_i$ , first determine which of the symbols  $X$ ,  $Y$  or  $Z$  would have to be transposed with the symbol  $A$  in  $\text{String}_i = e_1 e_2 e_3 e_4$  in order to toggle that same  $j$ th bit relative to the map  $F_{3,4}$ . Suppose that it is  $X$ , where  $e_b = X$ , and where  $e_a = A$  in  $\text{String}_i$ , and that  $X_i$  is in position  $c$  in  $s$ . Recall that  $\text{String}_i$  relates to a certain set of eight positions in  $s$ , among which are the two positions corresponding to  $e_a$ . By definition of  $e_a$  these two positions contain no  $X, Y, \text{ or } Z$ , and one of them is in fact position  $c + 2(a-b)$ , located at an even distance from the position  $c$  of  $X_i$ . It follows that to toggle the  $j$ th bit in question it suffices to transpose  $X_i$  with the symbol in position  $1$ , and then transpose  $X_i$  with the symbol in position  $c + 2(a-b)$ . For a toggling procedure in case it is  $Y$  or  $Z$  to be transposed with the symbol  $A$  in  $\text{String}_i$  in order to toggle that  $j$ th bit relative to the map  $F_{3,4}$ , replace each occurrence of the symbol  $X$  in the previous two sentences by  $Y$  or  $Z$  respectively. ■

The following corollary allows us to interpolate the result of theorem 4 for star networks whose dimension is not of the form  $13k+2$ .

Corollary:  $Q(11k+2-i) \implies S^2(13k+2-i)$  for  $i = 0, 1, 2, \dots, 10$ , with  $i \leq 5k+1$ .

Proof: The proof of theorem 4 would go through essentially the same way had we started with  $i$  fewer  $T$  symbols in positionally representing  $S(13k+2-i)$ , and the resulting map  $F$  would have  $i$  fewer  $\tau$  bits in defining its output. The result still holds for  $i > 10$ , but only the cases  $i \leq 10$  turn out to be useful. ■

The previous results of this section account for our best dilation 2 embeddings of hypercubes into star networks of dimension 9 or more. In the remainder of the section we use our one-to-many dilation 1 embedding schemes in a divide-and-conquer approach to form one-to-many dilation 2 embeddings that serve as our best embeddings for stars of dimension less than 9.

Theorem 5: If  $Q(k) \implies S^1(n)$  and  $Q(k') \implies S^1(n')$ , then  $Q(k+k'+1) \implies S^2(n+n')$ .

Proof: Let  $S(n)$  be  $A_1$ -represented on the symbols  $A_1, A_2, \dots, A_n$ , let  $S(n')$  be  $B_1$ -represented on the symbols  $B_1, B_2, \dots, B_{n'}$ , and let  $S(n+n')$  be  $A_1$ -represented on the symbols  $A_1, A_2, \dots, A_n$ ,

$B_1, B_2, \dots, B_n$ . Let  $F: R \rightarrow V(Q(k))$  and  $F': R' \rightarrow V(Q(k'))$  be one-to-many dilation 1 embeddings, where  $R \subseteq V(S(n))$  and  $R' \subseteq V(S(n'))$ . For  $x \in R$  (resp.  $x' \in R'$ ) and  $1 \leq i \leq n$ , let  $f_i(x)$  (resp.  $f'_i(x')$ ) denote an element of the set  $F_i(x)$  (resp.  $F'_i(x')$ ). For any string  $y$  let  $g(y)$  denote the string formed by replacing any occurrences of symbol  $A_1$  by  $B_1$ , while replacing any occurrences of symbol  $B_1$  by  $A_1$ . Let  $R''$  denote the set of those strings in  $S(n+n')$  of the form  $x;x'$  for which either  $x \in R$  and  $x' \in R'$ , or else  $g(x) \in R$  and  $g(x') \in R'$ . For  $x;x' \in R''$  define  $F'': R'' \rightarrow Q(k+k'+1)$  as follows. If  $x \in R$  then  $F''(x;x') = F(x);F'(x');\text{Sign}(x;x')$ , and otherwise  $F''(x;x') = F(g(x));F'(g(x'));\text{Sign}(x;x')$ .

We now show that  $F''$  is a one-to-many dilation 2 embedding. To toggle bit  $k+k'+1$  (the last bit) of  $x;x'$ , interchange the positions of  $A_1$  and  $B_1$ . Suppose in  $x;x'$  that  $x \in R$ . To toggle bit  $i$ ,  $1 \leq i \leq k$ , first (as  $F$  assures us is possible) interchange  $A_1$  with the appropriate symbol in  $x$  to get  $f_i(x);x'$ , and then interchange  $A_1$  and  $B_1$  to get  $g(f_i(x));g(x')$ . To toggle bit  $i$ ,  $k+1 \leq i \leq k+k'$ , first interchange  $A_1$  and  $B_1$  to get  $g(x);g(x')$ , then interchange  $A_1$  with the appropriate symbol in  $g(x')$  (in the manner dictated by  $F'$  with  $A_1$  playing the role of  $B_1$ ) to get  $g(x);g(f'_{i-k}(x'))$ . Lastly, suppose in  $x;x'$  that  $g(x) \in R$ . To toggle bit  $i$ ,  $1 \leq i \leq k$ , first interchange  $A_1$  and  $B_1$  to get  $g(x);g(x')$ , and then interchange  $A_1$  with the appropriate symbol in  $g(x)$  to get  $f_i(g(x));g(x')$ . To toggle bit  $i$ ,  $k+1 \leq i \leq k+k'$ , first interchange  $A_1$  with the appropriate symbol in  $x'$  (in the manner dictated by  $F'$  with  $A_1$  playing the role of  $B_1$ ) to get  $x;g(f'_{i-k}(g(x')))$ , and then interchange  $A_1$  and  $B_1$  to get  $g(x);g(f'_{i-k}(g(x')))$ . These toggling actions are summarized in the table below. It follows that  $F''$  is a one-to-many dilation 2 embedding. ■

	If $1 \leq i \leq k$	If $k+1 \leq i \leq k+k'$
If $x \in R$ .	$g(f_i(x));g(x')$	$g(x);g(f'_{i-k}(x'))$
If $x \notin R$ (i.e. $g(x) \in R$ )	$f_i(g(x));g(x')$	$g(x);g(f'_{i-k}(g(x')))$

A table indicating a point at distance 2 from  $x;x'$ , depending on whether  $x \in R$  and whether  $1 \leq i \leq k$ .

Corollary: We have the following one-to-many dilation 2 embeddings;  $Q(1) \Rightarrow S^2(2)$ ,  $Q(2) \Rightarrow S^2(3)$ ,  $Q(4) \Rightarrow S^2(4)$ ,  $Q(4) \Rightarrow S^2(5)$ ,  $Q(5) \Rightarrow S^2(6)$ ,  $Q(5) \Rightarrow S^2(7)$ ,  $Q(7) \Rightarrow S^2(8)$ .

Proof: With the exception of the claim  $Q(4) \Rightarrow S^2(4)$ , all parts of the corollary follow by applying the theorems 5 and 2 with appropriate choices of  $k$ ,  $k'$ ,  $n$ , and  $n'$ . As for  $Q(4) \Rightarrow S^2(4)$ , the map  $f: Q(4) \rightarrow S(4)$  given explicitly below serves as a dilation 2 one-to-one map in which  $S(4)$  is A-represented on ABCD, completing the proof.

$x \in Q(4)$	$f(x) \in S(4)$	$x \in Q(4)$	$f(x) \in S(4)$
0000	ABCD	1000	CABD

0001	BDCA	1001	BCAD
0011	BADC	1011	ACDB
0010	DBAC	1010	CBDA
0100	BACD	1100	ACBD
0101	BDAC	1101	BCDA
0111	ABDC	1111	CADB
0110	DBCA	1110	CBAD.



#### 4. Dilation 3 and 4 embeddings

Once we allow the dilation to exceed 2, our results so far indicate no known advantage in allowing one-to-many embeddings. So for the remainder of the paper we are concerned with ordinary (i.e. one-to-one) dilation  $d$  embeddings of  $Q(k)$  into  $S(n)$ . However, because  $\text{TranS}(n) \subseteq S^3(n)$ , the next results are concerned with embedding  $Q(k)$  into  $\text{TranS}(n)$ .

**Lemma 1:** If  $Q(k) \subseteq \text{TranS}(n)$  and  $Q(k') \subseteq \text{TranS}(n')$  with  $n \leq n'$ , then  $Q(k+k'+n) \subseteq \text{TranS}(n+n')$ .

**Proof:** Let  $\text{TranS}(n+n')$  be represented on the symbols  $a_1, a_2, \dots, a_n, A_1, A_2, \dots, A_{n'}$ . Each  $v \in Q(k+k'+n)$  is expressible uniquely in concatenated form  $V = v; v'; v''$  where  $v \in Q(k)$ ,  $v' \in Q(k')$ , and  $v'' \in Q(n)$ . Let  $f$  and  $f'$  be dilation 1 embeddings of  $Q(k)$  into  $\text{TranS}(n)$  and of  $Q(k')$  into  $\text{TranS}(n')$  respectively. For  $v \in Q(k+k'+n)$  let  $f''(v)$  be the string obtained from  $f(v); f'(v')$  as follows: for each of  $i = 1, 2, \dots, n$  for which  $v_i'' = 1$ , interchange the positions of  $a_i$  and  $A_i$ . The map  $f''$  is illustrated in Figure 4.

We now prove that  $f''$  is a dilation 1 embedding of  $Q(k+k'+n)$  into  $\text{TranS}(n+n')$ . That  $f''$  is one-to-one easily follows from the fact that  $f$  and  $f'$  are one-to-one. Suppose that  $V, W$  are adjacent in  $Q(k+k'+n)$ . If  $(v'')_i \neq (w'')_i$ , then  $f''(W)$  is obtainable from  $f''(V)$  by transposing the positions of  $a_i$  and  $A_i$ . If  $(v)_i \neq (w)_i$ , then  $f''(W)$  is obtainable from  $f''(V)$  by transposing the positions of two symbols in  $f(v)$ . Letting  $j_1$  and  $j_2$  be the positions of these symbols in  $f(v)$ , we see that  $f''(W)$  is obtainable from  $f''(V)$  by transposing the symbols in positions  $j_1$  and  $j_2$  of  $f''(V)$ . Lastly, if  $(v')_i \neq (w')_i$ , then  $f''(W)$  is obtainable from  $f''(V)$  by transposing the positions of two symbols in  $f'(v')$ . Letting  $j_1$  and  $j_2$  be the positions of these symbols in  $f'(v')$ , we have that  $f''(W)$  is obtainable from  $f''(V)$  by transposing the symbols in positions  $j_1+n$  and  $j_2+n$ . Therefore regardless of the coordinate in which  $V$  and  $W$  disagree,  $f''(V)$  and  $f''(W)$  are adjacent in  $\text{TranS}(n+n')$ , and the lemma follows. ■

**Lemma 2:** If  $Q(k) \subseteq \text{TranS}(n)$ , then  $Q(k + \lfloor \log_2(n+1) \rfloor) \subseteq S^3(n+1)$ .

**Proof:** Let  $S(n+1)$  be positionally represented on the symbols  $A, 1, 2, \dots, n$  and let  $\text{TranS}(n)$  be represented on the symbols  $1, 2, \dots, n$ . Let  $f'$  be a dilation 1 embedding of  $Q(k)$  into  $\text{TranS}(n)$ , and let  $L = \lfloor \log_2(n+1) \rfloor$ . Each  $x \in Q(k+L)$  is expressible uniquely as  $x'; x''$ , where  $x' \in Q(k)$  and  $x'' \in Q(L)$ . Define the map

$$f: Q(k+L) \rightarrow S(n+1)$$

by letting  $f(x)$  be the string obtained from the string  $A; f'(x')$  by transposing the symbols in positions  $1 + \text{Integer}(x'')$  and 1. Intuitively, the position of the symbol  $A$  corresponds to the value of the string  $x''$ , with the other positions in  $f(x)$  being the same as they are in  $f'(x')$ .

We now prove that  $f$  is a dilation 3 embedding of  $Q(k+L)$  into  $S(n+1)$ . That  $f$  is one-to-one follows from the fact that both  $f'$  and  $\text{Integer}$  are one-to-one. Suppose that  $x$  and  $y$  are adjacent points in  $Q(k+L)$ . If  $(x'')_i \neq (y'')_i$ , then  $f(x)$  has  $A$  in position  $1 + \text{Integer}(x'')$  while  $f(y)$  has  $A$  in

the different position  $1 + \text{Integer}(y'')$ . Hence  $f(y)$  is obtainable from  $f(x)$  by transposing the positions of the symbols in positions  $1 + \text{Integer}(x'')$  and 1 (to obtain the string  $A; f'(x') = A; f'(y')$ ) and then transposing the positions of the symbols in positions  $1 + \text{Integer}(y'')$  and 1. Since this involves only two transpositions of the type  $(1,j)$ , it follows that  $f(x)$  and  $f(y)$  are adjacent in  $S^3(n+1)$ . If  $(x')_i \neq (y')_i$ , then  $f(y')$  is obtainable from  $f(x')$  by transposing the symbols in some two positions. Thus  $A; f'(y')$  is obtainable from  $A; f'(x')$  by a single transposition. Since  $\text{Integer}(y'') = \text{Integer}(x'')$ ,  $f(y)$  is obtainable from  $f(x)$  by a single transposition, so  $x$  and  $y$  are adjacent in  $\text{TranS}(n+1)$  and consequently adjacent in  $S^3(n+1)$ . Therefore  $f$  is a dilation 3 embedding of  $Q(k+L)$  into  $S(n+1)$ , completing the proof. ■

The preceding lemmas are now used to prove the main result of this section.

**Theorem 6:** Let the sequence  $k_i, i \geq 1$ , be defined recursively by  $k_1 = 0$  and  $k_n = k_{\lfloor n/2 \rfloor} + k_{\lceil n/2 \rceil} + \lfloor n/2 \rfloor$ . Let  $L_n = \lfloor \log_2(n+1) \rfloor$ . Then we have the following embeddings:

- a)  $Q(k_n) \subseteq \text{TranS}(n)$  for  $n \geq 1$ .
- b)  $Q(k_n + L_n) \subseteq S^3(n+1)$  for  $n \geq 1$ .
- c)  $Q(n2^{n-1}) \subseteq \text{TranS}(2^n) \subseteq S^3(2^n)$  for  $n \geq 0$ .

Proof: We prove a) by induction, using  $Q(k_1) = Q(0) = \text{TranS}(n)$  as the base. For the inductive step, assume that a) holds for all values of  $n$  less than  $N \geq 1$ , so that in particular it holds when  $n$  is each of  $m = \lfloor N/2 \rfloor$  and  $m' = \lceil N/2 \rceil$ . Then it follows from lemma 1 that

$$Q(k_N) = Q(k_m + k_{m'} + m) \subseteq \text{TranS}(m + m') = \text{TranS}(N),$$

proving a) for all  $n$ .

Part b) is just a direct application of lemma 2 to the result in a). Finally, it is an easy induction to show that  $k_{2^n} = n2^{n-1}$ , from which c) is seen to be just a special case of a). ■

Parts b) and c) of theorem 6 summarize our best known results for embedding hypercubes into star networks with dilation 3. Our one-to-many dilation 1 and dilation 2 embedding schemes were such that the ratio of the star network dimension to the hypercube dimension was asymptotic to a constant. As seen by part c) of theorem 6, this ratio is asymptotic to  $\frac{2}{n}$  for our dilation 3 embeddings, where  $n$  is the  $\log_2$  of the star network dimension.

Finally we note that all of our results carry over (with different dilation constants) when  $S(n)$  or  $\text{TranS}(n)$  is replaced by the pancake graph  $P(n)$  discussed in the introduction. To see this it suffices to show that any transposition  $(1,i)$  applied to a string in  $S(n)$  is a product of at most  $D$  of the prefix reversals  $\rho_k$  for some constant  $D$ . For then any two strings  $x$  and  $y$  of  $S(n)$  satisfying  $\text{dist}_{S(n)}(x,y) \leq$

$L$  must also satisfy  $\text{dist}_{P(n)}(x,y) \leq DL$ . Consequently a dilation  $L$  result for  $S(n)$  yields a dilation  $DL$  result for  $P(n)$ .

We show that  $D \leq 4$ . Let  $AxBY$  be a string in  $S(n)$ , positionally represented, where  $A$  and  $B$  are letters while  $x$  and  $y$  are strings. Also denote by  $x^R$  the reversal of the string  $x$ . Then a sequence of four prefix reversals leading from  $AxBY$  to  $BxAy$  is given by  $AxBY \rightarrow x^RABY \rightarrow xABY \rightarrow Ax^RBY \rightarrow BxAy$ . Thus for example theorem 4 yields the dilation 8 one to many embedding result  $Q(11k+2) \Rightarrow P^8(13k+2)$ , and likewise for other theorems.

Similarly, for  $xAyBz$  a string as above, the sequence  $xAyBz \rightarrow Ax^RyBz \rightarrow By^RxAz \rightarrow yBxAz \rightarrow y^RBxAz \rightarrow x^RByAz \rightarrow xByAz$  demonstrates that any transposition  $(i,j)$  is a product of at most 6 of the prefix reversals  $\rho_k$ . Therefore an immediate consequence of theorem 6c is that  $Q(n2^{n-1}) \subseteq \text{Trans}(2^n) \subseteq P^6(2^n)$ , and similarly for theorem 6a.

#### 4. Open Problems

1. Let  $f(k)$  be the minimum integer  $n$  for which a one to many map  $Q(k) \Rightarrow S^1(n)$  exists. The definition of  $Q(k) \Rightarrow S^1(n)$  implies that for such an  $n$  and  $k$  the degree of any vertex in  $S(n)$  must be at least as large as the degree of any vertex in  $Q(k)$ . Hence  $f(k) \geq k+1$ . On the other hand Theorem 2 shows that  $f(k) \leq 3k-2$ . We leave it as an open problem as to where this minimum  $f(k)$  generally lies in the interval between  $k+1$  and  $3k-2$ . We note that the lower bound  $f(k) = k+1$  holds for  $k=3$  (again by Theorem 2), and conjecture that it never holds for  $k > 3$ .

2. Find cases (other than the ones discussed in this paper) where one to many embeddings offer some advantage over one to one embeddings. That is, find triples  $(k,n,d)$  for which a one to one map  $Q(k) \rightarrow S(n)$  of dilation at most  $d$  is either impossible or "hard" to find, but for which a one to many map  $Q(k) \Rightarrow S^d(n)$  can be constructed.

3. Investigate the issue of one to many maps between families of computationally interesting graphs besides the hypercubes and star networks. For example, consider one to many maps  $Q(k) \Rightarrow P^d(n)$ , where  $P(n)$  is the "pancake" graph discussed in the introduction. As mentioned above, our results carry over to maps  $Q(k) \Rightarrow P^d(n)$ , but only by the route  $Q(k) \Rightarrow S^r(n) \subseteq P^d(n)$  for some  $r$  given in our theorems, where  $d$  might be as large as  $4r$ . This may yield a higher dilation  $d$  than could be obtained by some "direct" construction of a map  $Q(k) \Rightarrow P^d(n)$ . See [F] for a systematic development of the subject of one to many embeddings between different families of graphs.

## References

- [AHK] S. Akers, D. Harel, and B. Krishnamurthy, "The star graph: an attractive alternative to the n-cube", Proc. of 1987 International Conference on Parallel Processing, pp. 393-400.
- [AK1] S. Akers and B. Krishnamurthy, "Group graphs as interconnection networks", Proc. of 14'th International Conference on Fault Tolerant Computing, (1984) pp.422-427.
- [AK2] S. Akers and B. Krishnamurthy, "A group-theoretic model for symmetric interconnection networks", IEEE Transactions on Computers, Vol. 38, No. 4 (1989), pp.555-566.
- [BCHLR] S. Bhatt, F. Chung, J-W. Hong, F.T. Leighton, and A. Rosenberg, "Optimal simulations by butterfly networks", Proc. of 23rd Annual ACM Theory of Comp. Sci. Conf. (1988), pp.192-204.
- [F] M. Fellows, "Encoding graphs in graphs", Ph.D. dissertation, Dept. of Computer Science, University of California - San Diego (1985).
- [GP] W. H. Gates and C. H. Papadimitriou, "Bounds for sorting by prefix reversal," Discrete Math., Vol. 27 (1979), pp.47-57.
- [MPS] Z. Miller, D. Pritikin, I.H. Sudborough, "Bounded dilation maps of hypercubes into Cayley graphs on the symmetric group", submitted.
- [MS] B. Monien and I.H. Sudborough, "Simulating binary trees on hypercubes", Proc. of 1988 AWOC Conference on VLSI Algorithms and Architectures (July 1988), in Lecture Notes in Computer Science, Vol. 319, (Springer Verlag) pp. 170-180.
- [NSK] M. Nigam, S. Sahni, and B. Krishnamurthy, "Embedding hamiltonians and hypercubes in star interconnection graphs", Proceedings of International Conference on Parallel Processing (1990).

Dimension n of star	$\lceil \log_2(n!) \rceil$	dilation 1*	dilation 2*	dilation 3	dilation 4	dilation 6	dilation 8
1	0	0	0	0	0	0	0
2	1	1	1	1	1	1	1
3	2	1	2	2	2	2	2
4	4	3	4	4	4	4	4
5	6	3	4	6	6	6	6
6	9	3	5	7	8	8	9
7	12	3	5	9	10	11	12
8	15	4	7	12	13	14	15
9	18	4	7	15	16	17	18
10	21	4	8	16	19	20	21
11	25	4	9	18	22	23	24
12	28	4	10	20	25	26	27
13	32	5	11	23	28	30	31
14	36	5	12	25	31	33	34
15	40	5	13	28	34	37	38
16	44	6	13	32	38	41	42
17	48	6	13	36	42	45	46
18	52	6	14	37	46	49	50
19	56	7	15	39	50	53	54
20	61	7	16	41	54	57	58
21	65	7	17	44	58	61	62
22	69	8	18	46	62	65	66
23	74	8	19	49	66	69	70
24	79	8	20	52	70	73	75
25	83	9	21	56	74	78	79
26	88	9	22	58	78	82	84
27	93	9	23	61	82	87	88
28	97	10	24	64	86	91	93
29	102	10	24	68	90	96	98
30	107	10	24	71	94	100	102
31	112	11	25	75	98	105	107
32	117	11	26	80	103	109	112

Table 1

Largest k for which it is known that  $Q(k)$  has a dilation d embedding into  $S(n)$ .

\* Indicates that one-to-many embeddings have been allowed.

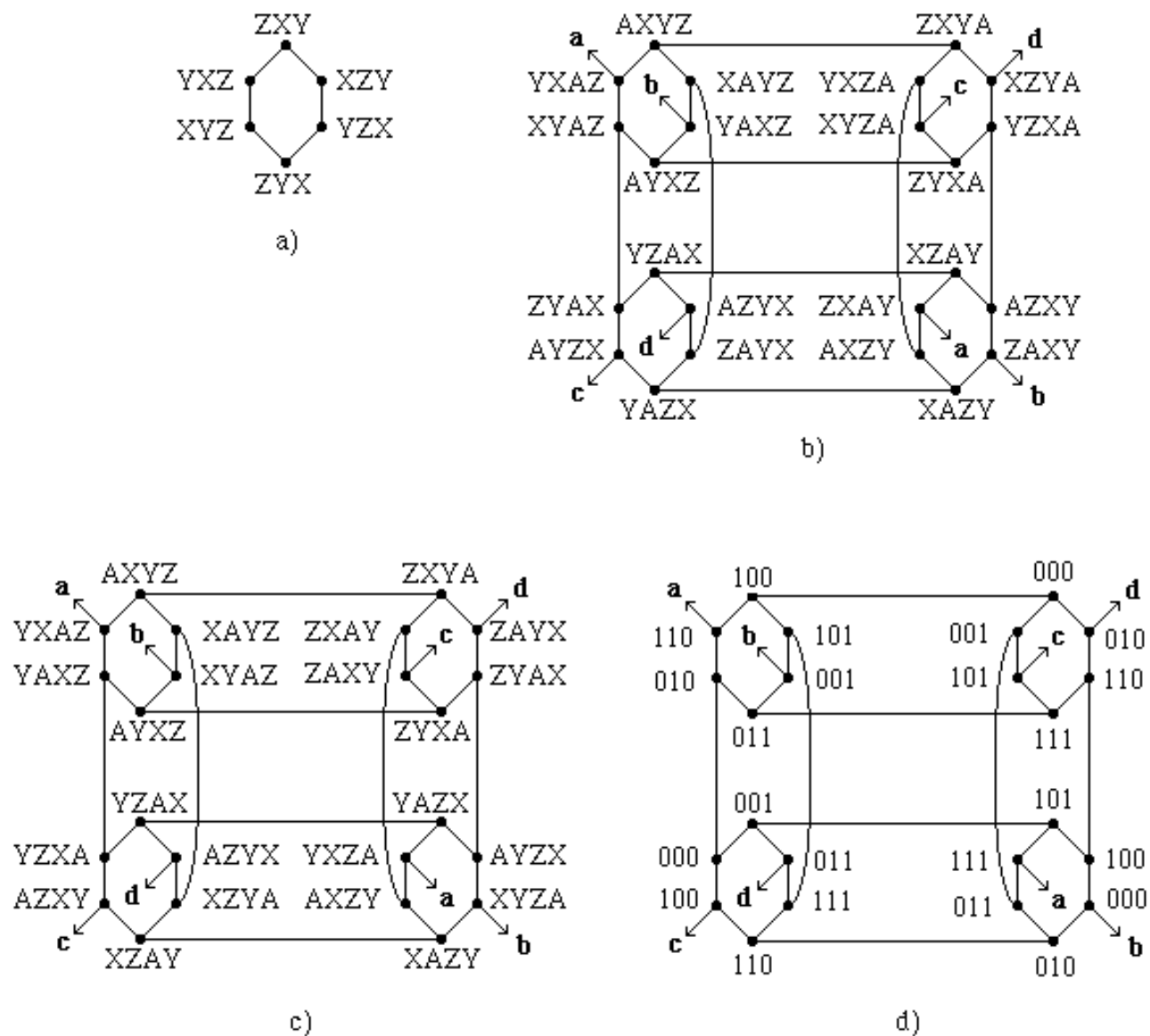

Figure 1

- a)  $S(3)$ , positionally represented on  $XYZ$ .  
 b)  $S(4)$ , positionally represented on  $AXYZ$ .  
 c)  $S(4)$ , A-represented on  $AXYZ$ .  
 d) In tandem with c), an illustration of the map  $F_{3,4}$ . The image of each vertex in c) is shown by the label of its corresponding vertex in d).



Figure 3:

The set  $R$  and corresponding map  $F$  taking input  $s \in R \subseteq S(13k+2)$  on top line and yielding  $F(s) \in Q(11k+2)$  on bottom line, illustrating theorem 4

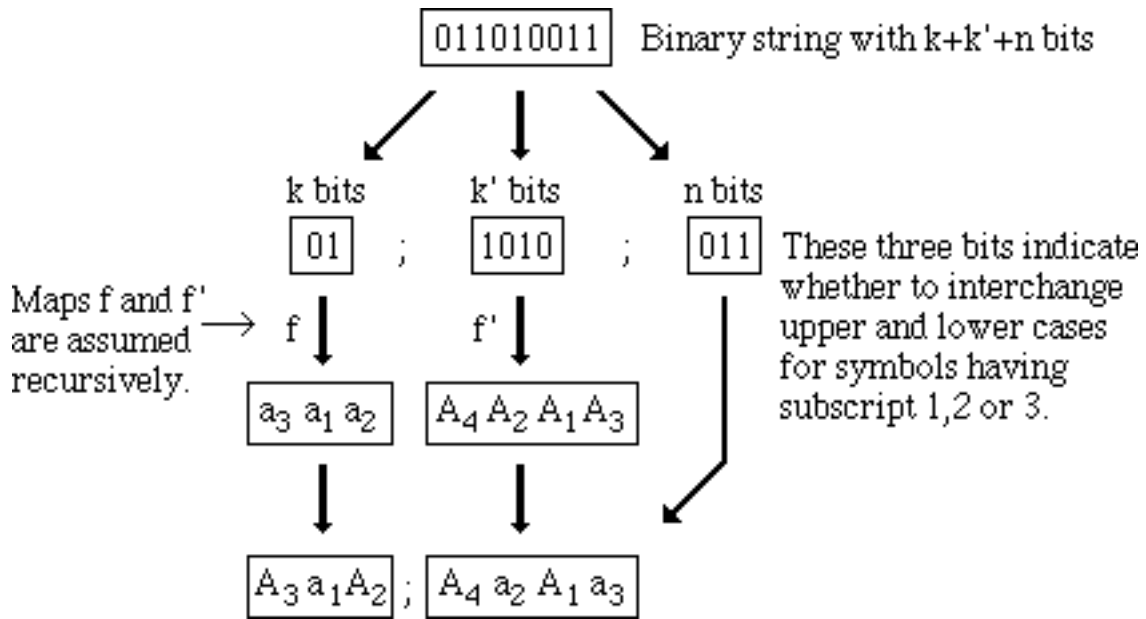

Figure 4: The construction of an embedding  $f':Q(k+k'+n) \subseteq \text{TranS}(n+n')$  from assumed embeddings  $f:Q(k) \subseteq \text{TranS}(n)$  and  $f':Q(k') \subseteq \text{TranS}(n')$