

# **PHY 420/520 Report Style Manual**

Herbert Jaeger  
Department of Physics  
Miami University, Oxford, OH

## **Abstract**

Instructions for preparation of laboratory reports are presented. The instructions are intended to provide guidance to authors in preparing reports for PHY 420 /520 experiments. The format of these instructions is that of a scientific journal paper to serve as an example for your own report. Examples of literature references, tables, and figures are included.

## **General Instructions**

Reports must be written in English, typed double-spaced throughout, on white paper 8 1/2 x 11 inches in size. Type on one side of the page only and leave a 1 inch margin at both sides and at top and bottom. Number all pages consecutively beginning with the title-abstract page. Include the following materials, in the order show:

- (a) Title page with title, authors and affiliation, and an abstract.
- (b) The main text of the report.
- (c) Acknowledgments (optional)
- (d) Appendices if necessary
- (e) Literature references and footnotes
- (f) Tables with captions
- (g) Figures with captions

Details as to the content and format requirements of (a) through (g) are given in the following sections.

### **Title Page**

This page contains the title, names and affiliations of the authors (in our case that would be Department of Physics, Miami University, Oxford, Ohio), and an abstract. The abstract is a concise summary of the report. Briefly state the purpose of the experiment, summarize the techniques used, outline what you have done, and include a summary of your results. The abstract must be complete and intelligible in its own; thus, do not refer to footnotes at the end of the paper, and define all abbreviations used. The abstract should not exceed 200 words.

### **The Main Text**

The main text of your report should be divided into five sections. Typical section headers are: *Introduction, Experimental Procedure, Results, Discussion, Conclusions (or Summary)*. In some cases it may be more convenient or appropriate to *present and discuss* the results in the same section. Then you would have four sections with typical headers: *Introduction, Experimental Procedure, Results and Discussion, Conclusions (or Summary)*. Which format to use depends on the nature and multitude of the data, and the authors' preference. Following is summary of what is expected to go in each section.

(i) Introduction: Present background and context of the experiment. If appropriate review the literature of similar work done by others and point out where your work fits in, i.e. what do you provide or improve that others have not done. Keep in mind that your reader is not familiar with your experiment. It is your job to point out the significance of your work and how it fits in with other work done in your field. In context of this course that means that you should write your report such that it can be read and understood by another physics student of junior or senior standing without being familiar with this particular class.

(ii) Experimental Procedure: This section contains a detailed description of the procedure followed, special parts needed including circuits and unusual instruments (e.g. digital storage oscilloscope, lock-in amplifier, etc.). This is not necessarily a chronological description of what you have done. When the experiment or your circuit finally works you probably will have tried all kinds of things, some of which may have not worked. There is usually no need to dwell on these failed attempts unless it is directly related to the project. For example, if a circuit is needed for the experiment and you tried various versions with different components, it is only necessary to present the final version of the circuit diagram, and not recount the various stages inbetween. If you developed software as part of your project to control the experiment or evaluate and analyze data, describe the program in this section. You may consider attaching a program printout as an appendix, but this is done only if unusual programming techniques were used. The discussion of software should be just detailed enough to understand what the program is doing, without going into gory details about how you implemented particular steps.

(iii) Results: In this section the results of your experiment are presented in a matter-of-fact way, i.e., without going into a discussion or comparison with theory. It is crucial to present the results in an organized fashion. Large amounts of data are best shown in a graphical display rather than columns of numbers. If exact numerical values need to be show-cased, a table may be more appropriate. Whenever numbers as a result of a measurement or calculated numbers based on measured values are reported you must attempt to include an uncertainty as a figure of merit. For example, if you measured the local acceleration due to gravity a result of  $g = 9.79 \text{ m/s}^2$  would not mean very much. You would not be able to tell whether another result of  $g = 9.85 \text{ m/s}^2$  (maybe measured by the group at the other end of the room) is consistent with yours, or if it must be considered different. Moreover, the number by itself does not allow any conclusions about the quality and capability of your experimental setup; is your experiment capable of detecting differences in  $g$  across the room, or is it merely able to confirm  $g$  in the general area of  $10 \text{ m/s}^2$ ?

Results reported as  $(9.79 \pm 0.08) \text{ m/s}^2$  and  $(9.85 \pm 0.05) \text{ m/s}^2$  indicate what your experiment can do, and shows that the two values are really the same within the reported uncertainties. A more compact way of writing the above results would be  $9.79(8) \text{ m/s}^2$  and  $9.85(5) \text{ m/s}^2$ , where the figure(s) in parentheses indicate the uncertainty of the last digit(s) reported.

(iv) Discussion: This is the place to discuss the significance of your results. To illustrate your points of discussion it may be necessary or helpful to replot some of your results in a different way as you may have done in the *Results* section. Remember, it is your intent to convince the reader of your interpretation of the experiment. Therefore you must choose the most persuasive way to present your arguments.

(v) Conclusion or Summary: The main points of the paper, including the conclusions you have drawn from your results, should be reiterated in this section. In a way this is where you could put in the same things that show up in the abstract without the restriction of saying it in 200 words or less.

### **Acknowledgment and Support**

If you wish to acknowledge support of any kind (e.g., if someone gave you a grant to perform the experiment) or contributions of other people than the authors (e.g., someone prepared a sample for you to do your experiment) it is done in this section.

### **Appendix**

If you have lengthy derivations of mathematical expressions, or you wish to include specific experimental procedures (such as special components to be used in a circuit, or certain “tricks” to make something work), or material that does not really fit in the main text, put them in an appendix. It may be appropriate to subdivide into Appendix A, Appendix B, etc. As already mentioned above, programs, VIs and such, if at all, should be included in the appendix.

### **Literature References and Footnotes**

References and footnotes are listed at the end of the report in the order of citation in the main text. Use superscript Arabic numerals running consecutively throughout the text. Below there are examples for citing a journal article<sup>1</sup> (authors, title of article, name of journal, volume (in bold

face), first page, year in parenthesis), citation of a book<sup>2</sup> (name of authors of the book or the chapter in the book, book title (underlined), editor (if any), publisher and place of publication and year (all three in same set of parentheses), citation of a lab manual<sup>3</sup>, and citation from an unpublished source, such as a thesis<sup>4</sup>.

1. H. Jaeger, J. A. Gardner, J. C. Haygarth, and R. L. Rasera, “Structural Characterization of High-Temperature Zirconia Ceramics by Perturbed Angular Correlation Spectroscopy”, *J. Am. Ceram. Soc.* **69**, 458 (1986).
2. R. M. Steffen and K. Alder, in The Electromagnetic Interaction in Nuclear Spectroscopy, edited by W. D. Hamilton (North-Holland, Amsterdam, 1965).
3. G. M. Julian, J. R. Priest, and John. W. Snider, PHY293 Contemporary Physics Laboratory Manual, Department of Physics, Miami University, Oxford, OH (1994).
4. L. J. Abu-Raddad, M.S. Thesis, Miami University (1994), unpublished.

## **Tables**

Each table should be presented on a separate sheet in the order in which they are cited in the main text. The table *must* be accompanied by a *table number* used in the text to reference the table and a *table caption* printed above the table next to the table number. The title should be chosen explicitly enough for the reader to understand the table without reading the main text. Refer to Table 1 and Table 2 as examples.

## **Figures**

Each figure should be presented on a separate sheet in the order in which they are cited in the main text. A figure may be a block diagram or circuit diagram (Fig. 1), a photograph of the lab or some device or sample, a sketch of a procedure (Fig. 2), or a graph of data or functions (Fig. 3). The figure *must* be accompanied by a *figure number* used in the text to reference the figure and a *figure caption* printed below the figure next to the number. The caption should be chosen explicitly enough for the reader to understand the figure without reading the main text. Refer to Figures 1, 2, and 3 as examples.

## **Summary**

For this “report” this section would look as follows. These instructions summarize the format requirements for the PHY420/520 laboratory reports. The sections are discussed in the order they should appear in the report. Examples for literature references, tables, and figures are included.

**Table 1:** Chemical Analyses zircon samples received from Teledyne Wah Chang, Albany, Oregon. The Australian zircons differ considerably from batch to batch; they are identified by the name of the ship (e.g. Great Harvest, etc.) that transports the mineral to the U.S.

<b>Origin</b>	<b>ZrO<sub>2</sub> HfO<sub>2</sub></b> [wt%]	<b>SiO<sub>2</sub> (free)</b> [wt%]	<b>Al<sub>2</sub>O<sub>3</sub></b> [wt%]	<b>TiO<sub>2</sub></b> [wt%]	<b>Fe<sub>2</sub>O<sub>3</sub></b> [wt%]	<b>P<sub>2</sub>O<sub>5</sub></b> [ppm]	<b>Ra</b> [μC/g]	<b>U</b> [ppm]	<b>Th</b> [ppm]	<b>Pb</b> [ppm]
Florida	67.4	N/A	0.22	0.1	0.05	950	87	280	140	36
Great Harvest	66.4	0.23	0.37	0.011	0.048	900	78	180	170	46
PacKing	66.6	0.005	0.37	0.14	0.05	750	77	245	180	57
Favorita	66.65	0.016	0.17	0.18	0.14	920	78	240	270	33

**Table 2:** Results of positron lifetime measurements on two different teflon samples. Teflon 2 is about 20 years older than Teflon 1. The higher positron lifetime of Teflon 2 indicates a different type of defect than observed in Teflon 1.

<b>Sample</b>	<b>Run</b>	<b>Lifetime [ps]</b>	<b>Error [ps]</b>
<b>Teflon 1</b>	1	2273	4
	2	2201	4
	3	2229	10
	4	2271	8
	5	2286	7
<b>Average 2.25(2) ns</b>			
<b>Teflon 2</b>	1	4104	11
	2	4079	9
	3	4055	11
	4	4145	15
	5	4104	10
	6	4080	8
<b>Average 4.01(3) ns</b>			

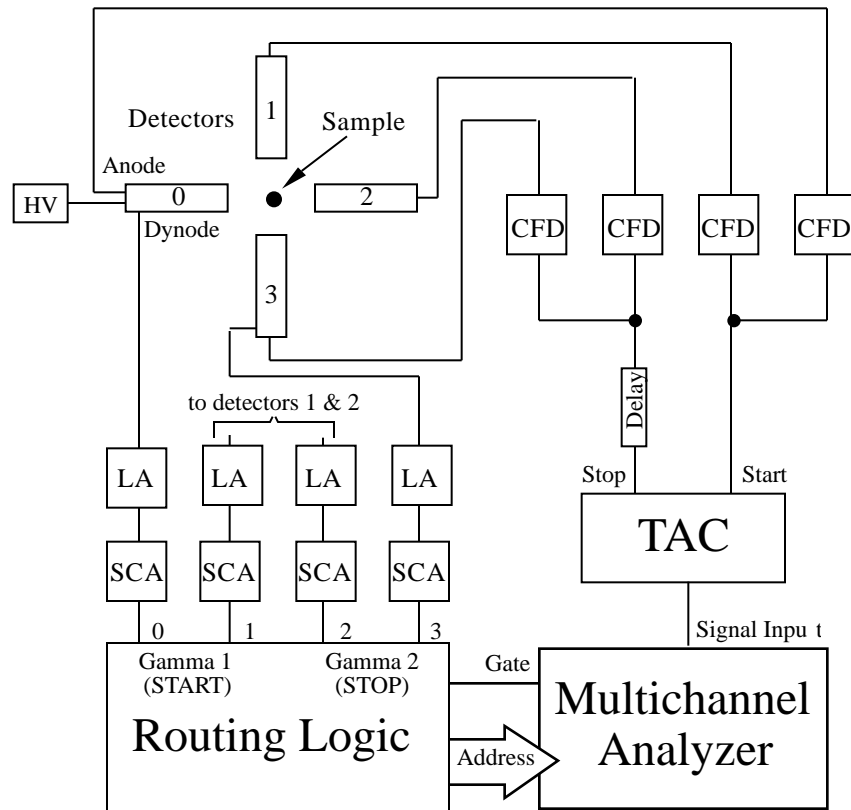

**Figure 1:** Block diagram of the PAC spectrometer used in this work. The anode signals of the detectors are shaped by constant fraction discriminators (CFD). The time-to-amplitude converter (TAC) is started by detector 0 or 1 and stopped by detector 2 or 3. The dynode signals of each detector are amplified by linear amplifiers (LA) and discriminated by single channel analyzers (SCA). A routing logic determines the memory sector of the multichannel analyzer in which the event will be stored.

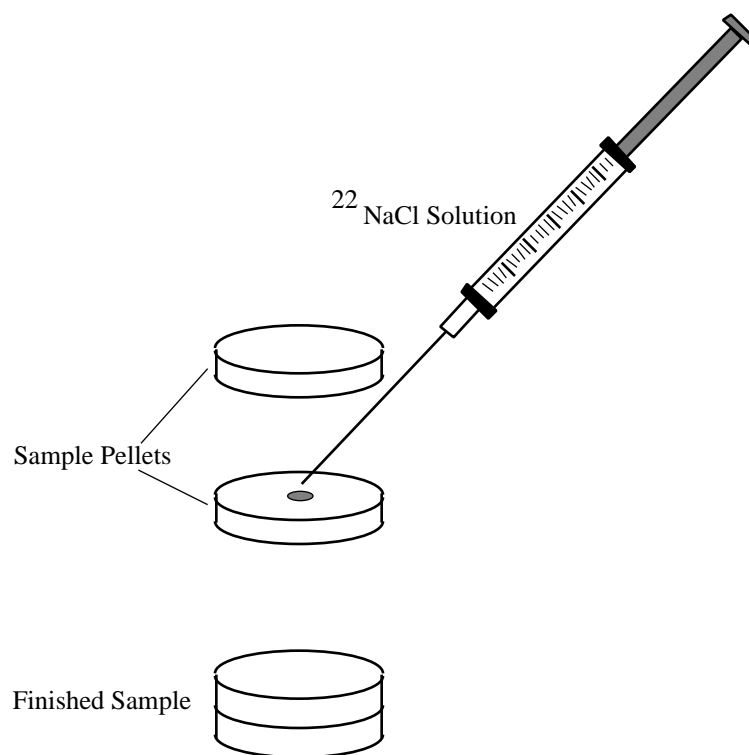

**Figure 2:** Preparation of a sample to measure the positron annihilation time. A small droplet of aqueous  $^{22}\text{NaCl}$  is deposited in the center of a sample pellet. After the water is allowed to evaporate the  $^{22}\text{NaCl}$  spot is covered by another pellet of the same material. In this way the majority of all positrons from the  $^{22}\text{Na} \rightarrow ^{22}\text{Ne}$  decay enter the sample material.

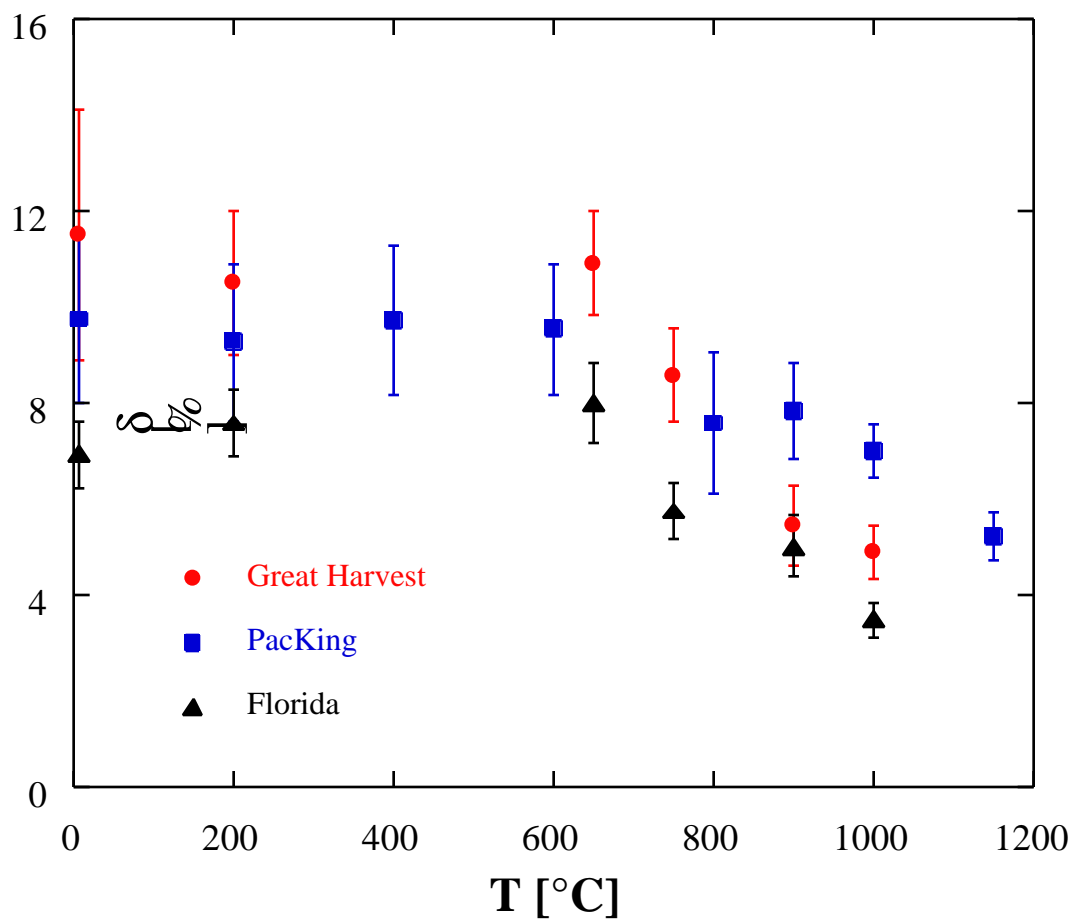

**Figure 3:** Line broadening *vs.* annealing temperature for the three zircon samples studied. Significant narrowing of spectral lines is observed after annealing at temperatures above 700°C.